

Pitchdeck

Start-ups



SUMMIT 2022



September 30th
Messe Stuttgart



Baden-Württemberg

MINISTRY OF ECONOMIC AFFAIRS, LABOUR AND TOURISM

**Find your
answers here:**



What is the Start-up BW Summit?

Start-up BW is the official start-up campaign of Baden-Württemberg and represents a high-performance network of partners from a variety of regional and institutional backgrounds.

With **Start-up BW**, Baden-Württemberg is taking start-up financing and professional support to a level of international excellence.

The **Start-up BW Summit** is an **international showcase**, event and network meeting for the campaign, for the scene, for **start-ups**, start-up **stakeholders** and start-up **ecosystems**.

Baden-Württemberg is the **Place 4B2B**. At the Start-up BW Summit start-ups meet **start-ups**, **corporates** and **SMEs**, **VCs** and **business angels**, who are looking for the **ideas of the future** and offer themselves as customers, partners and mentors with venture capital offers and accelerator programs.

Network partners from consulting, promotion and technology transfer, **private and public start-up stakeholders** and **start-up ecosystems** present their ideas, exchange views, network and learn from each other **internationally, on every level**.

That was the Start-up BW Summit 2019 ...

**400 Start-ups, including
75 from 16 International
Ecosystems**



**200 Network Partners from
consulting, promotion and
technology transfer**



**5,000
Participants**

Partner Country: Israel

More than 250
Start-up Pitches

4 Stages with 3 Keynotes,
7 Top Class Speakers and
6 Success Stories on the panel



400 B2B-Partners from Large
and Medium-sized Enterprises

25,000 m² Start-up
Culture live with 2.5
times as much Exhibition
Space as the first
Start-up Gipfel 2017

Unfortunately, the
Start-up BW Summit 2020
had to be cancelled due to the
Corona pandemic.



WHAT

Start-up BW Summit 2022

WHAT: Start-up BW Summit 2022

... and this year,
Start-up BW presents:

one full day of start-up culture in THE LÄND

Start-up BW Summit 2022

the highlight event for start-ups in Baden-Württemberg &

**TÜBINGEN
AI CENTER**

conference on artificial intelligence and start-ups –
bridging cutting-edge research on AI with hands-on solutions



WHAT: Start-up BW Summit 2022

In September 2022 we will experience:

1 Day Fair & Congress | 5.000 Participants | up to 200 international Start-ups in 7 industry and technology fields | focus topic AI | Pitch Competition | International Start-up Ecosystems & AI Initiatives | Incubators & Accelerators | Corporates & Investors | Success Stories | Best Practices | Networking | Matchmaking | Top Class Speakers |

and much more ...

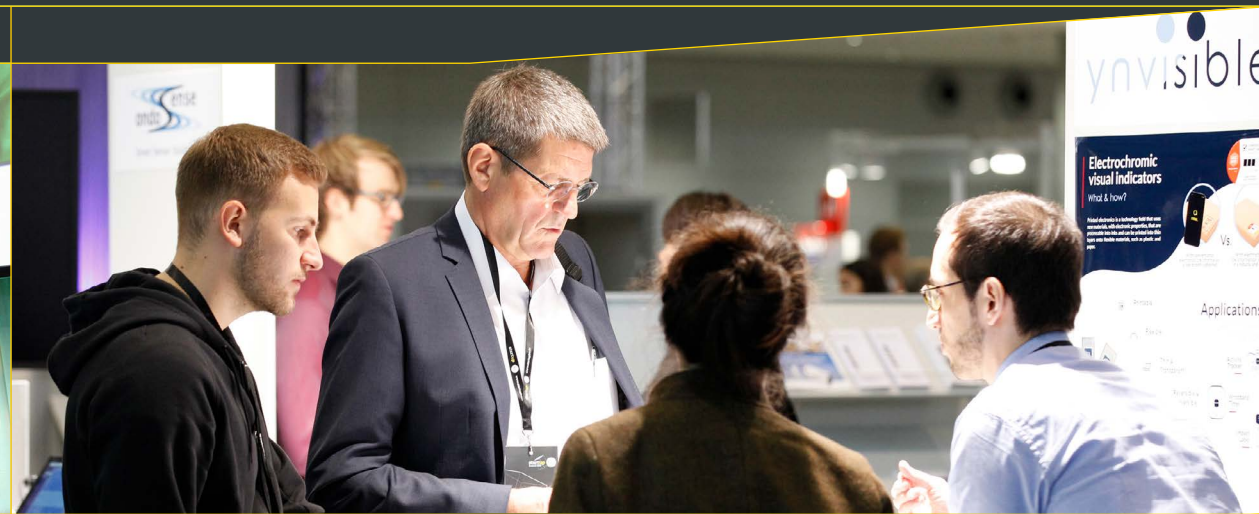
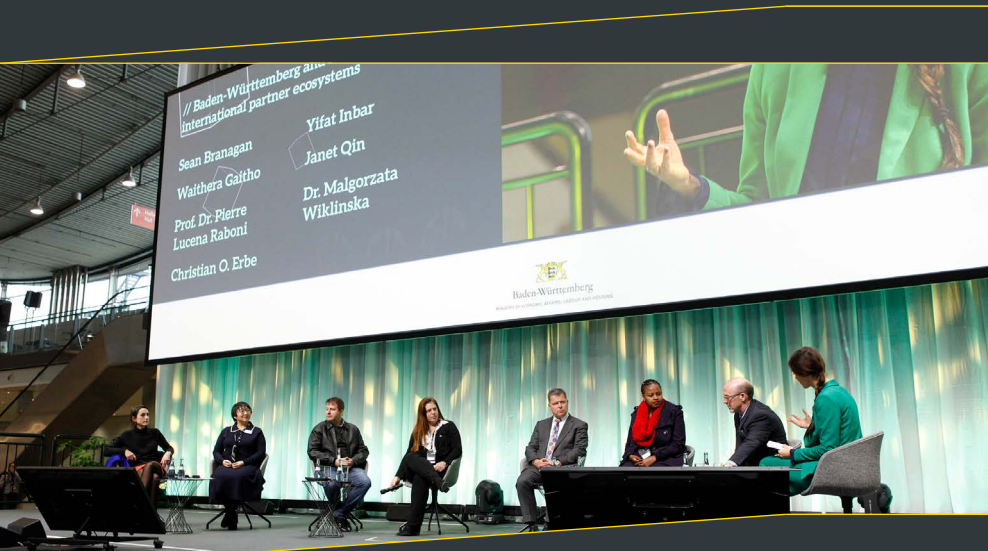



WHO

Start-up BW, the international start-up scene and you!

WHO: ... you!

Be a fundamental part of the Start-up BW Summit 2022 as an exhibitor!

For us, quality takes precedence over quantity – up to 200 exhibition spaces exclusively reserved for the best start-ups from all over the world.

We define start-ups as ...

- ... early phases of pilot projects, usually up to a maximum of 5 years after foundation
- ... growth-oriented / scalable business-model
- ... innovative
- ... often tech or service-driven
- ... generally international focused
- ... assignable to one of our seven clusters:
 - Artificial Intelligence | Energy & Environment |
 - E-Services & FinTech | Life Sciences & MedTech |
 - Manufacturing & Mobility | Social Innovation & GovTech |
 - Software & IT Security





WHY

For you!

WHY: For you!

- 1. Network**
with other start-ups, relevant start-up stakeholders and start-up ecosystems from Baden-Württemberg, Europe and the world.
- 2. Present your ideas**
to a broad audience of B2B partners, corporates, SMEs, VCs and business angels.
- 3. Attract**
reference customers, business partners, investments, R&D cooperation partners and upcoming talents.
- 4. Find out**
more about the scene, current trends and technologies.
- 5. Learn more**
about best practices and success stories.
- 6. Experience**
top class speakers, start-up culture and the AI scene.
- 7. Get ready**
for a successful international start!

WHY: For you!

... and all this for a small cost contribution.

The exhibition stand at the Start-up BW Summit 2022 is financed by the Ministry of Economics, Labour and Tourism Baden-Württemberg. You only need to pay a participation fee of 250 € (including VAT).

Your benefits ...

- ... a ready-to-use exhibition stand with your branding – find more details
- ... extra space for an exhibit, if you need it
- ... a starting position in our pitch competition
- ... end-to-end support and service for queries, when preparing your exhibition appearance
- ... online presence on our channels
 - presence on the event website
 - company profile in the participants tool for the event and access to the digital matchmaking area
- ... 1x long term parking ticket



WHY: For you!

International Pitch Competition

You not only get an exhibition stand but also a stage!
 Your audience: our expert jury and numerous corporates and SMEs,
 VCs, business angels and potential partners and multipliers.
 Attract the right partners for your project – and win the competition!

Details:

- Pitches will be made in the following clusters:
 - Artificial Intelligence
 - Energy & Environment
 - E-Services & FinTech
 - Life Sciences & MedTech
 - Manufacturing & Mobility
 - Social Innovation & GovTech
 - Software & IT Security
- 3 minutes talk time (in English)
- There will be time for questions after the pitches at your stand
- For each cluster, the first to third place will be selected on site by a jury, receive an award on the main stage at the end and presented with a cash prize.
- The pitches can be made using supporting slides





HOW

Your registration

HOW: Your application

“A lot of different start-up ideas from various sectors. The participation fee is very low. Great networking opportunities.”

“A great exhibition, very dynamic, great talks and stands with start-up people and partners.”

Apply now at:

<https://summit.startupbw.de/>

1st application deadline: 23rd of May 2022

2nd application deadline: 4th of July 2022

“There was a lot going on, we were answering questions the whole time, met great people and had fun!”

“We not only had lots of interesting business contacts and potential partner firms, but also visits from the Chamber of Industry and Commerce (IHK), the mayor of my home town and the business development agency. I was also engaged as the keynote speaker for an event in Heilbronn.”

Details of Exhibition Appearances

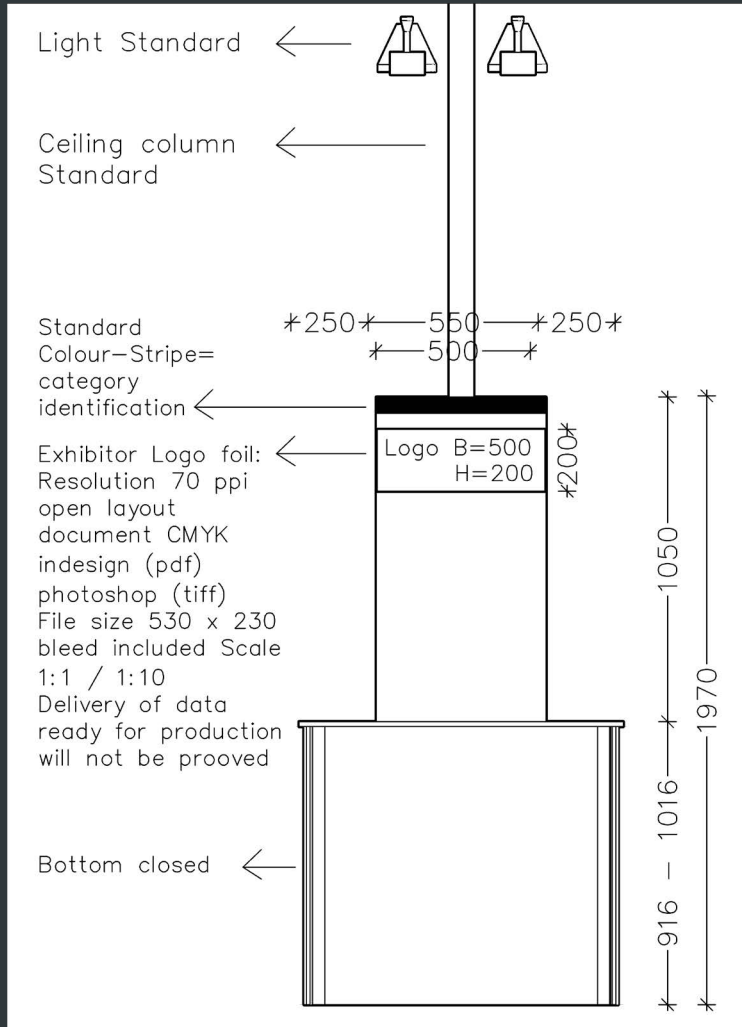
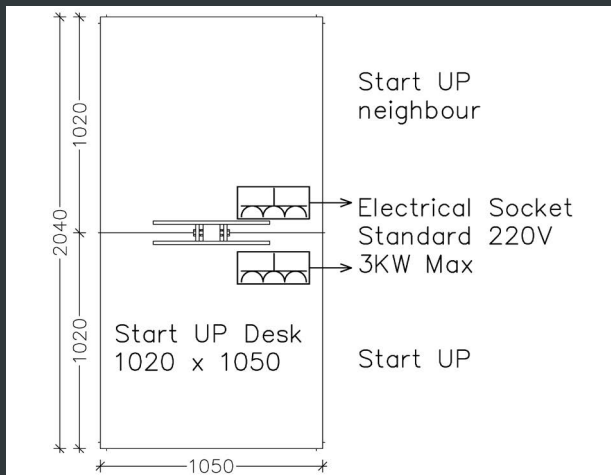
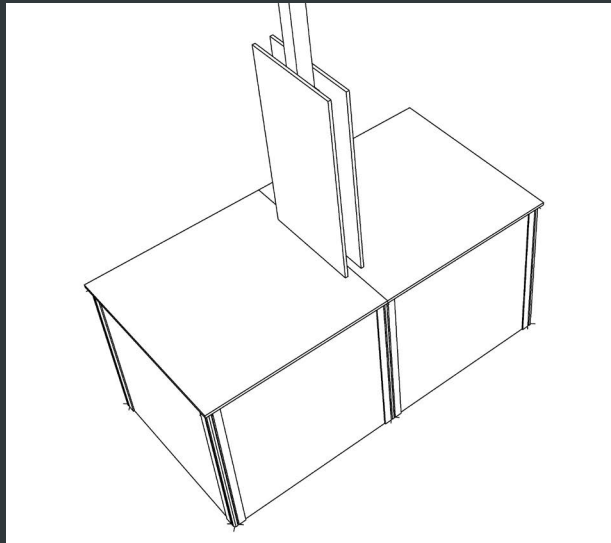

Standard facilities / furnishing is as follows:

- 1 start-up desk (102 x 105 cm) on the island stand (island stands are clustered in our 7 industrial fields)
- 1 electrical socket (3x standard 220V / 3 KW max)
- Logo print at the head of the presentation desk